

REVISIONS

P	LTR	DESCRIPTION	DATE	DWN	APVD

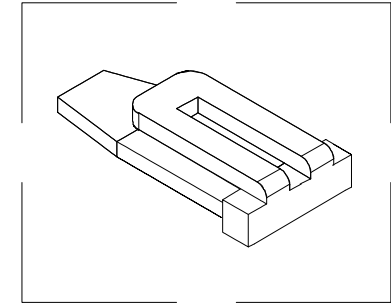
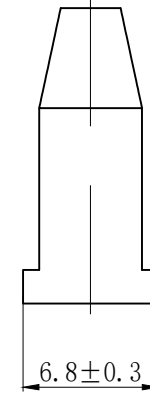
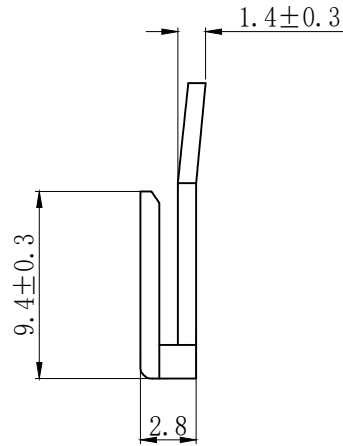
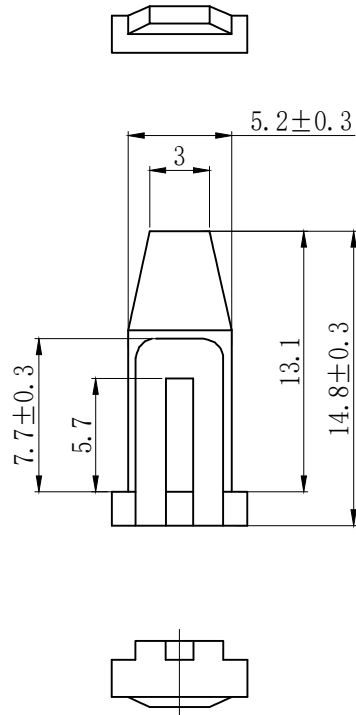

Specifications:

1. Materials: PA66 UL94 V0
2. Colors: natural (white)
3. Matching plastic parts: 35181-0200

THIS DRAWING IS A CONTROLLED DOCUMENT.		Design 2018-02-08 WANLEFU	Yueqing Hegxing Electronic Co., Ltd		
		Checked 2018-02-08 YUNJIAN LIN			
DIMENSIONS: mm	TOLERANCES ACCORDING TO THE DRAWING SPECIFIED	Approved 2018-02-08 WEIHUA LIN	NAME Connector		
		PRODUCT SPEC	APPLICATION SPEC	SIZE A4	GAGE CODE
WEIGHT		RESTRICTED TO			
CUSTOMER DRAWING			SCALE	SHEET 1 OF 1	REV

REVISIONS

P	LTR	DESCRIPTION	DATE	DWN	APVD

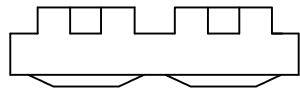
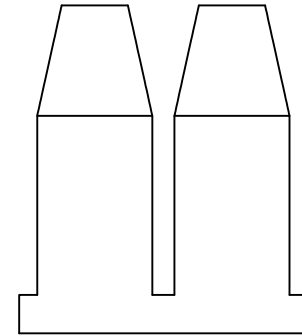
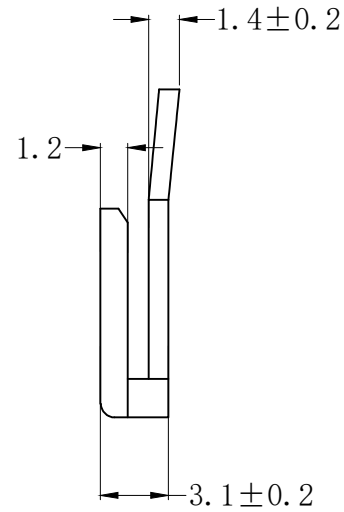
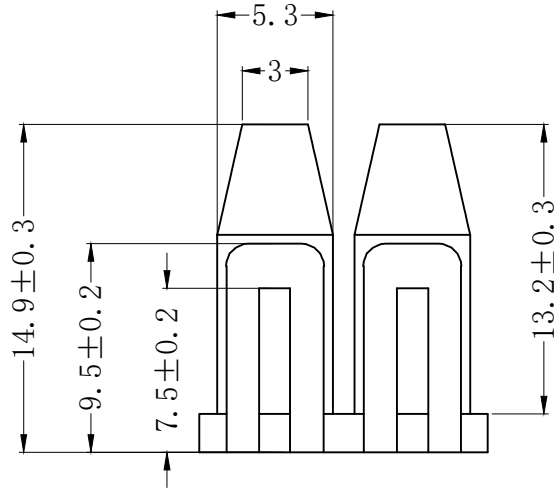
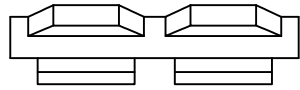

Specifications:

1. Materials: a. PA66 UL 94 V2
2. Colors: 0290 :natural ,0292:Red ,0293: yellow,0294:Blue
3. Housin inserts cooperate: OK

THIS DRAWING IS A CONTROLLED DOCUMENT.		DROWN 2006-12-08 ARONG PAN	Yueqing Hegxing Electronic Co.,ltd			
DIMENSIONS: mm		Checked 2006-12-08 YUNJIAN LIN	NAME 6.2 pitch connector T.P.A			
TOLERANCES ACCORDING TO THE DRAWING SPECIFIED		Approved 2006-12-8 WEIHUA LIN	PRODUCT SPEC			
		APPLICATION SPEC	SIZE	GAGE CODE	DRAWING NO	RESTRICTED TO
UL-94 V2		WEIGHT	A4		35150-029*	
CUSTOMER DRAWING					SCALE	SHEET 1 OF 1
					REV	

REVISIONS

P	LTR	DESCRIPTION	DATE	DWN	APVD

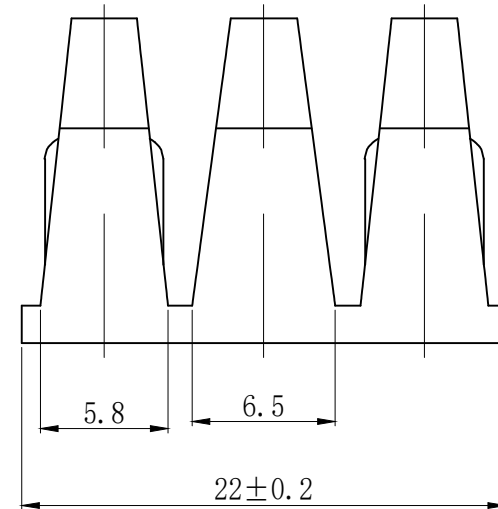
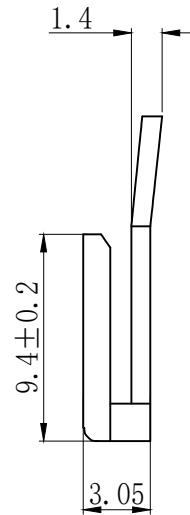
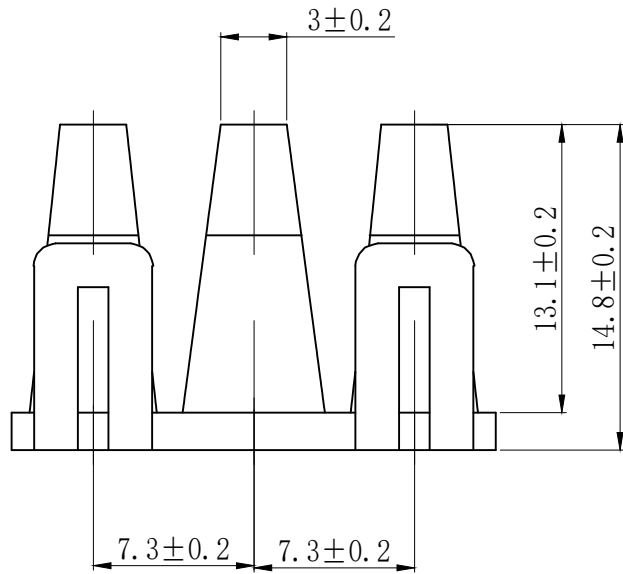
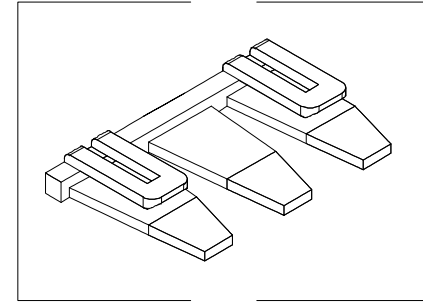
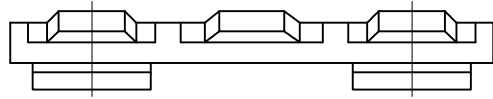

Specifications:

1. Materials: a. PA66 UL 94 V2
2. Colors: Natural: 35150-0390, Red: 35150-0392
Yellow, 35150-0393, Blue: 35150-0394
3. Housin inserts cooperate: OK

THIS DRAWING IS A CONTROLLED DOCUMENT.		DROWN 2006-12-08 ARONG PAN	Yueqing Hegxing Electronic Co.,Ltd			
		Checked 2006-12-08 YUNJIAN LIN				
DIMENSIONS: mm	TOLERANCES ACCORDING TO THE DRAWING SPECIFIED	Aproved 2006-12-8 WEIHUA LIN	NAME connector T.P.A			
		PRODUCT SPEC	SIZE	GAGE CODE	DRAWING NO	RESTRICTED TO
	UL-94 V2	APPLICATION SPEC	A4	35150-039*	1 OF 1	REV
		WEIGHT				