

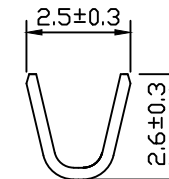

REVISIONS

P	LTR	DESCRIPTION	DATE	DWN	APVD

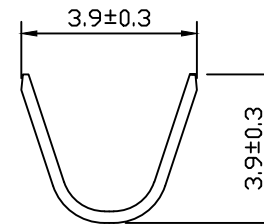
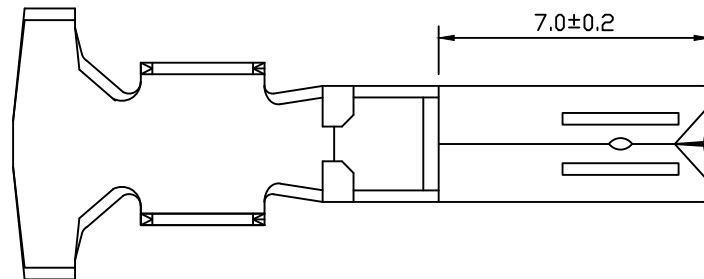
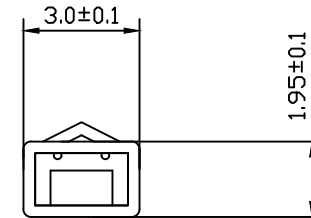
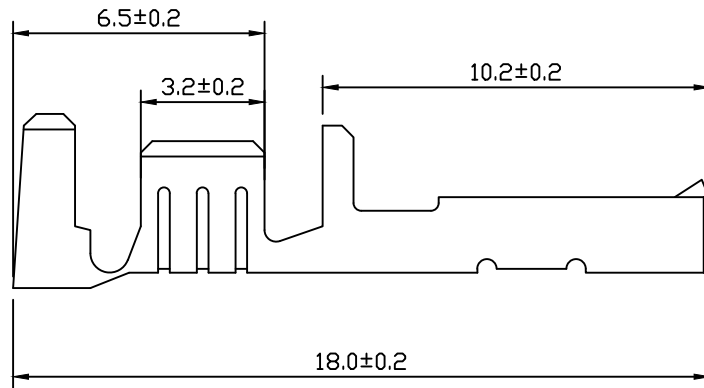

Specifications:

1. Applicable Wires: AWG22-20#
2. Material: 0.3mm Brass
3. Finish: Pre-plated Tin

THIS DRAWING IS A CONTROLLED DOCUMENT.	DROWN 21-02-2009 ARONG PAN	Yueqing Hegxing Electronic Co.,ltd			
	Checked 23-04-2009 YUNJIAN LIN	NAME			
DIMENSIONS: MM	Approved 13-05-2009 DUQING LI	070 B TYPE FEMALE TERMINAL			
 TOLERANCES ACCORDING TO THE DRAWING SPECIFIED.	PRODUCT SPEC	SIZE	GAGE CODE	DRAWING NO	RESTRICTED TO
	APPLICATION SPEC	A4		35748-0110	
Material: 0.30 mm BRASS	FINISH: TIN PLATED	WEIGHT	CUSTOMER DRAWING		SCALE SHEET 1 OF 1 REV

REVISIONS

P	LTR	DESCRIPTION	DATE	DWN	APVD

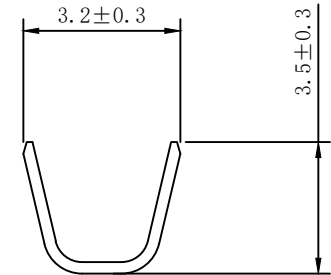
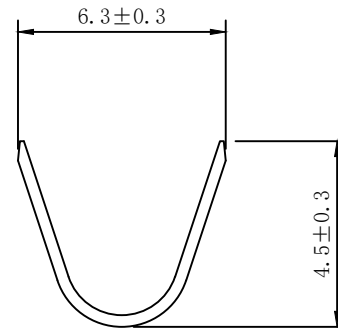
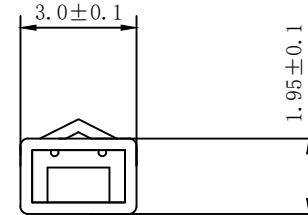
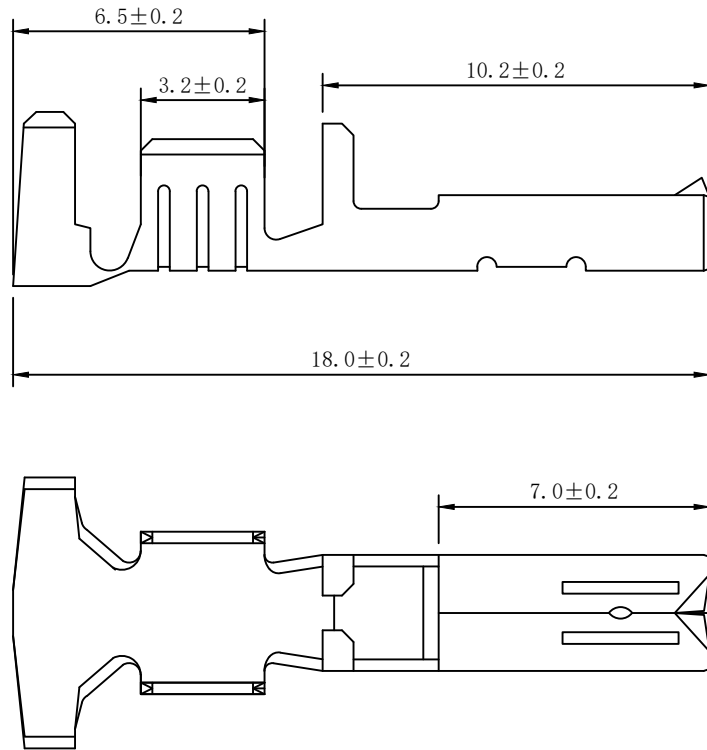

Specifications:

1. Applicable Wires: AWG18-14#
2. Material: 0.3mm PHOSPHOR BRONZE
3. Finish: Pre-plated Tin

THIS DRAWING IS A CONTROLLED DOCUMENT.		DROWN 21-02-2009 ARONG PAN	Yueqing Hegxing Electronic Co.,ltd			
DIMENSIONS: MM		Checked 23-04-2009 YUNJIAN LIN	NAME			
TOLERANCES ACCORDING TO THE DRAWING SPECIFIED.		Approved 13-05-2009 DUQING LI	070 B TYPE FEMALE TERMINAL			
		PRODUCT SPEC	SIZE	GAGE CODE	DRAWING NO	RESTRICTED TO
Material: 0.30 mm BRASS		FINISH: TIN PLATED	A4		35748-0210	
CUSTOMER DRAWING				SCALE	SHEET 1 OF 1	REV

REVISIONS

P	LTR	DESCRIPTION	DATE	DWN	APVD

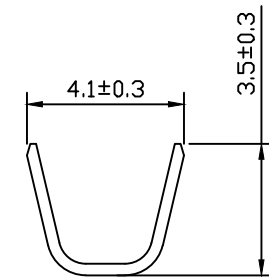
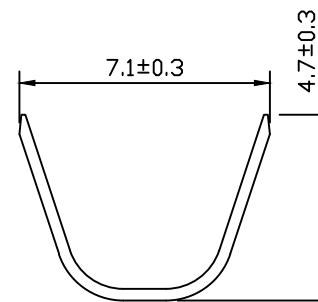
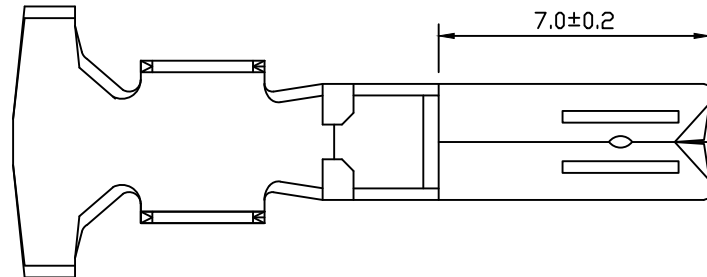
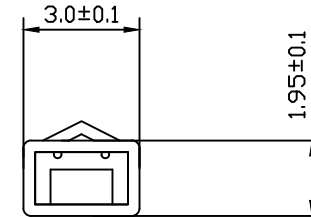
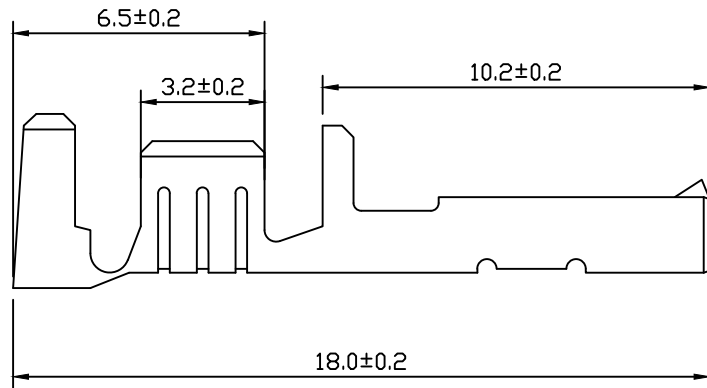

Specifications:

1. Applicable Wires:

AWG20#+20# or AWG20#+18# or AWG18#+18#

2. Material: 0.3mm Brass

3. Finish: Pre-plated Tin

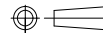
THIS DRAWING IS A CONTROLLED DOCUMENT.		DROWN 21-02-2009 ARONG PAN	Yueqing Hegxing Electronic Co.,ltd		
DIMENSIONS: MM		Checked 23-04-2009 YUNJIAN LIN	NAME		
TOLERANCES ACCORDING TO THE DRAWING SPECIFIED.		Approved 13-05-2009 DUQING LI	070 B TYPE FEMALE TERMINAL		
		PRODUCT SPEC	SIZE	GAGE CODE	DRAWING NO
Material: 0.30 mm BRASS		FINISH: TIN PLATED	A4		35748-0310
CUSTOMER DRAWING			RESTRICTED TO	SCALE	SHEET 1 OF 1
			REV		

REVISIONS

P	LTR	DESCRIPTION	DATE	DWN	APVD

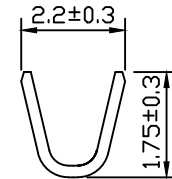
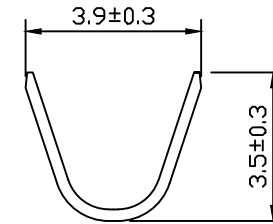
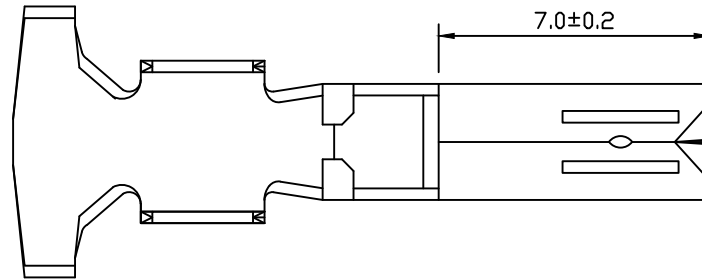
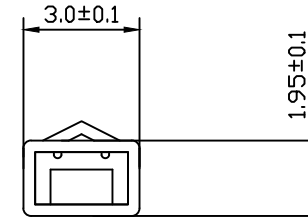
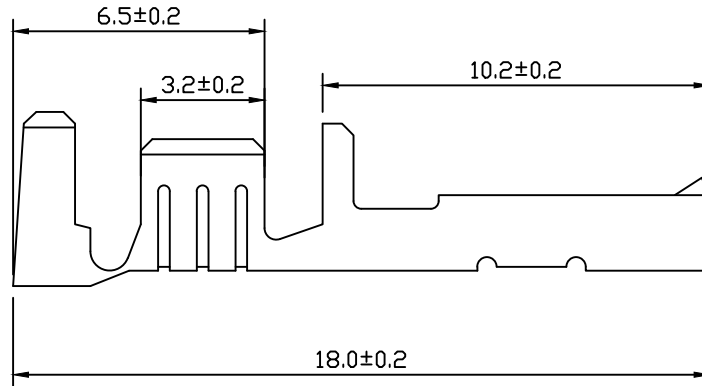

Specifications:

1. Applicable Wires: AWG24-22#
2. Material: 0.3mm PHOSPHOR BRONZE
3. Finish: Pre-plated Tin

THIS DRAWING IS A CONTROLLED DOCUMENT.		DROWN 21-02-2009 ARONG PAN	Yueqing Hegxing Electronic Co.,ltd		
DIMENSIONS: MM		Checked 23-04-2009 YUNJIAN LIN	NAME		
TOLERANCES ACCORDING TO THE DRAWING SPECIFIED.		Approved 13-05-2009 DUQING LI	070 B TYPE FEMALE TERMINAL		
		PRODUCT SPEC	SIZE	GAGE CODE	DRAWING NO
Material: 0.30 mm BRASS		FINISH: TIN PLATED	A4		35748-0410
CUSTOMER DRAWING			RESTRICTED TO	SCALE	SHEET 1 OF 1
			REV		